

L'IMPIANTO ELETTRICO DIVENTA CONNESSO



**Attiva lo
scenario
principessa**

Soluzioni d'impianto

Domotica

Sistema intelligente connesso,
impianto con funzioni complete

**Impianto
tradizionale**

Nessuna funzione
centralizzata

Soluzioni d'impianto

Domotica

Sistema intelligente connesso,
impianto con funzioni complete

Smart-Home

Singoli oggetti connessi,
impianto con funzioni base

**Impianto
tradizionale**

Nessuna funzione
centralizzata

Soluzioni d'impianto

Domotica

Ideale per grandi appartamenti, ville e terziario e per clienti predisposti alla tecnologia

Molteplici funzioni implementabili nel tempo (gestione energia, diffusione sonora, termoregolazione)

Integrabile con sistemi di terze parti

Necessita di un cablaggio dedicato ed è indicato nel nuovo e nelle ristrutturazioni complete

Smart-Home

Ideale per il residenziale

Adatto per le ristrutturazioni parziali (non necessita di opere murarie)

Possibilità di gestire anche solo piccole parti dell'impianto

Basso impatto economico rispetto al "tradizionale"

Facile da spiegare e di semplice utilizzo per l'utente

Smart-Home

Semplicità

Connettività

Integrazione

Semplicità

Smart-Home

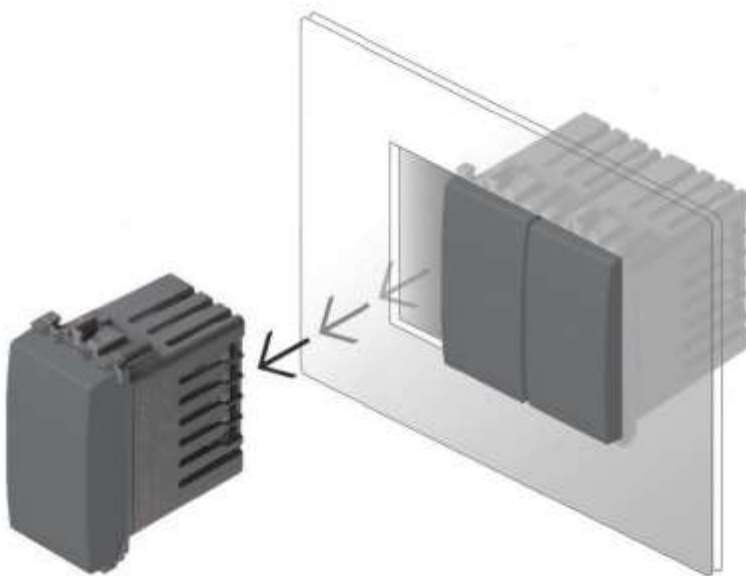

Ristrutturazione

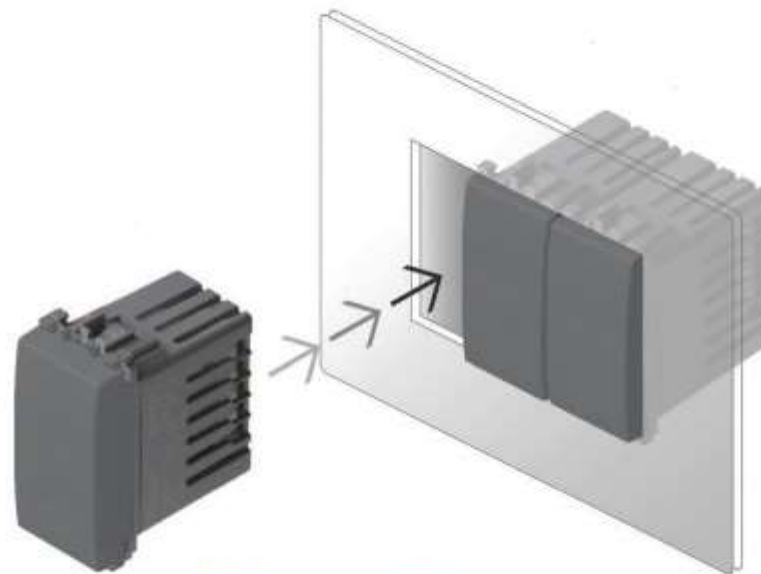

Aggiornamento
Impianto

Nuovo edificio

Smart-Home



Configurazione

Creazione ambienti

Associazione dispositivi

Parametrizzazione

Verifica e collaudo



Connettività

Smart-Home



Illuminazione

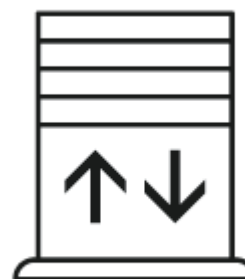
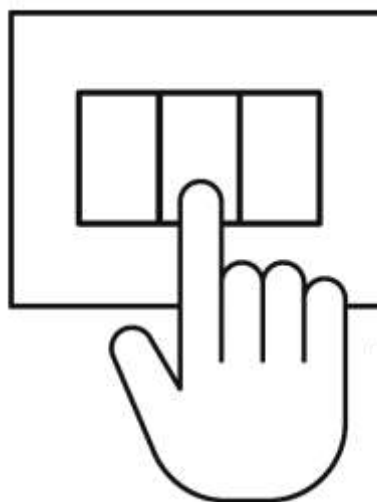

Tapparelle

Smart-Home

Comando luci connesso

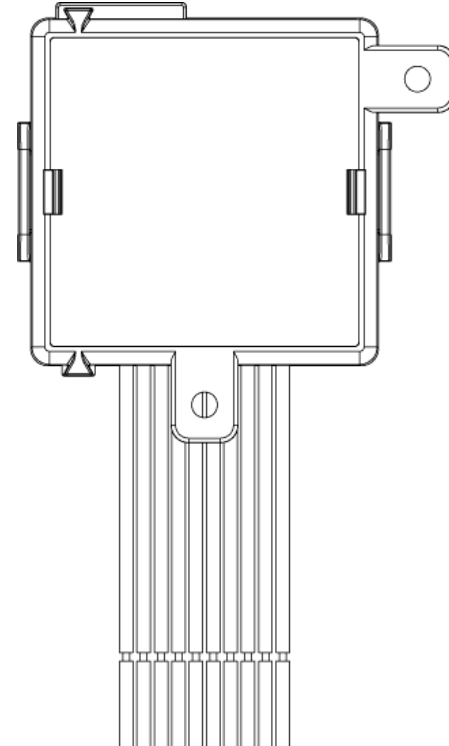

Smart-Home

Comando luci connesso



Retroilluminazione per individuazione al buio/stato del carico

Relè integrato

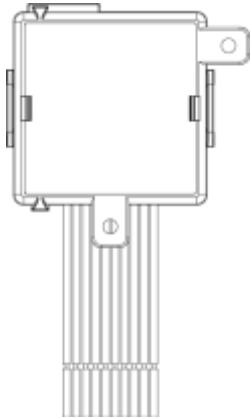

Possibilità di estensione con comandi wireless

Smart-Home

Comando luci connesso

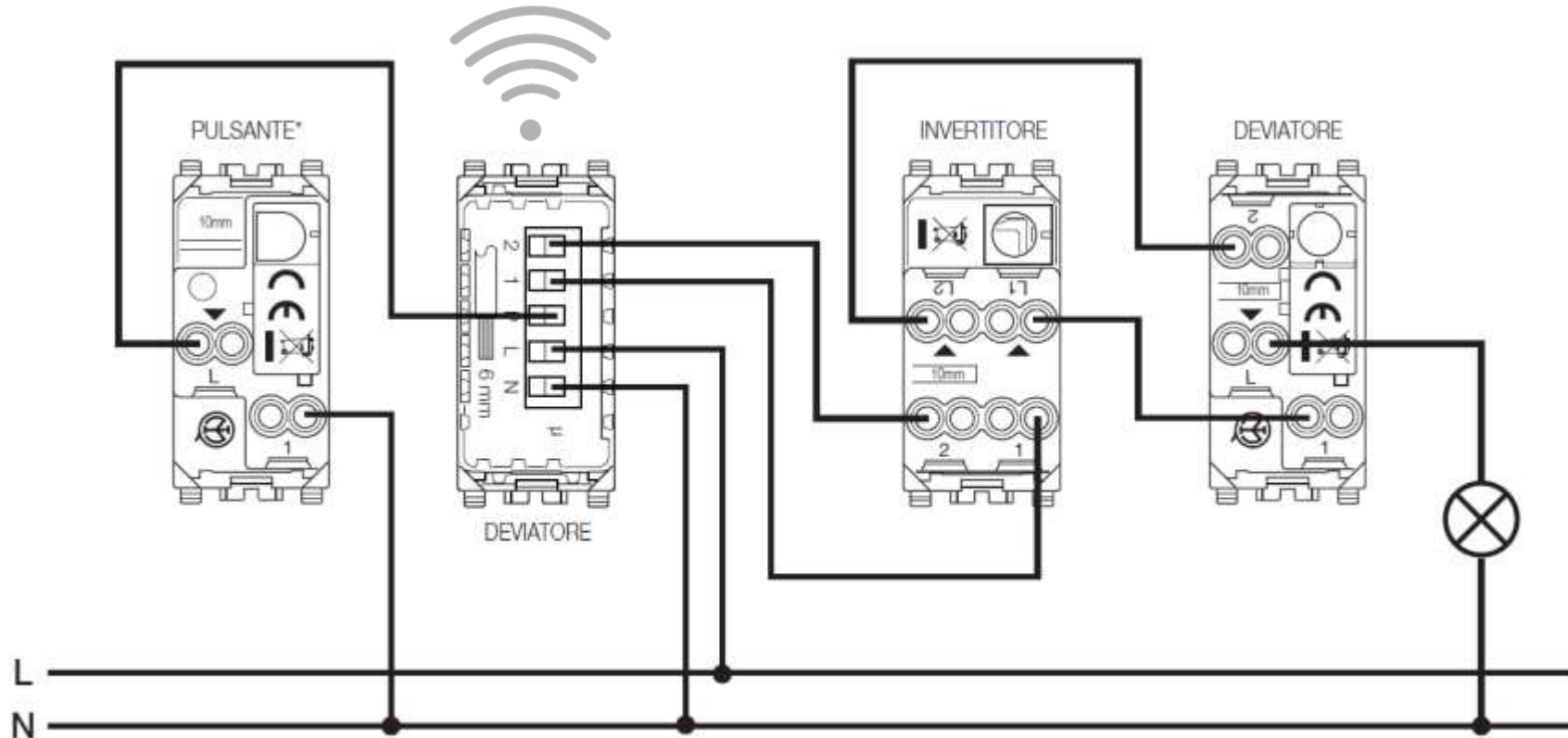

Smart-Home

Comando luci connesso

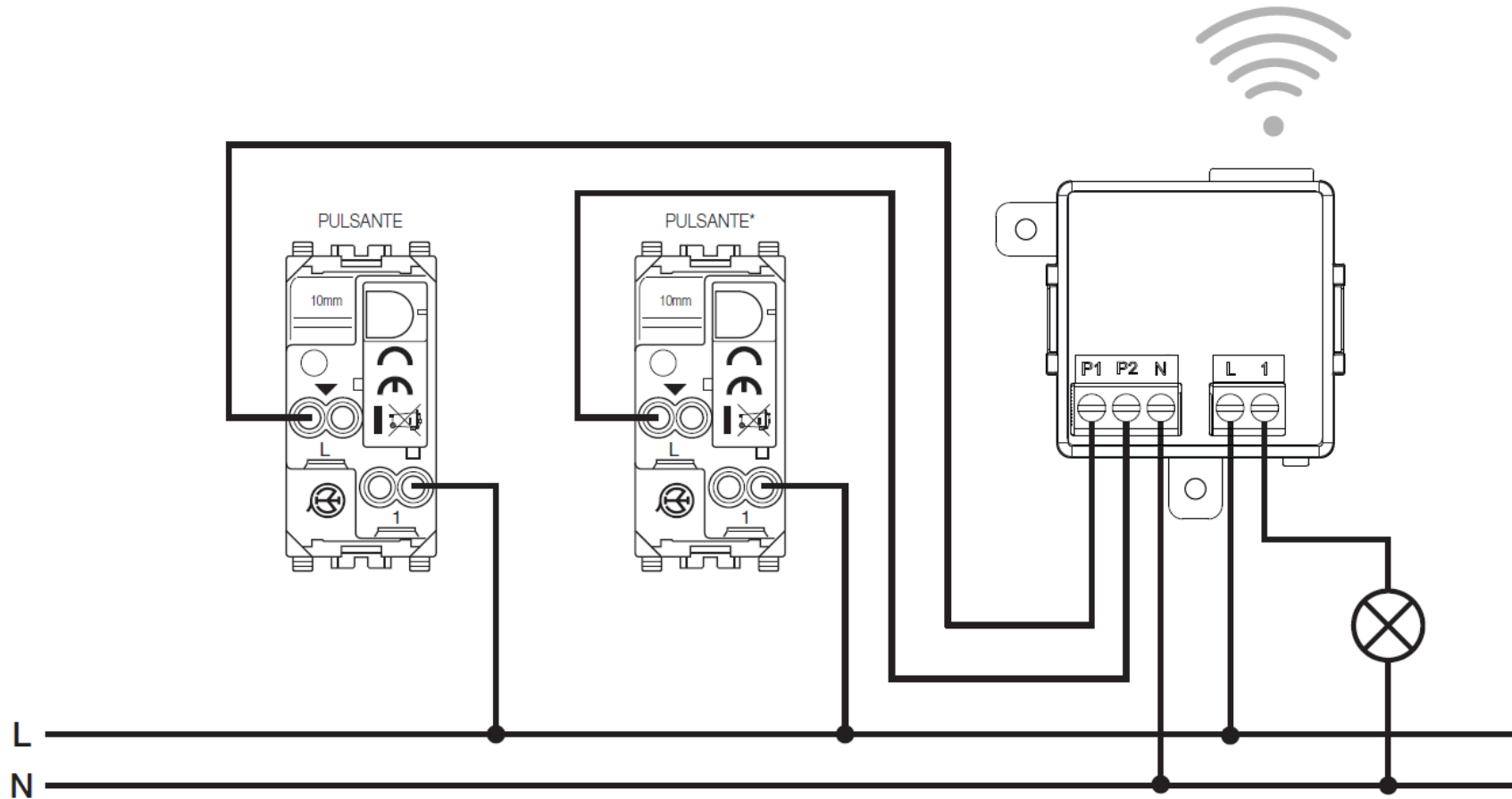

Smart-Home

Comando tapparella connesso

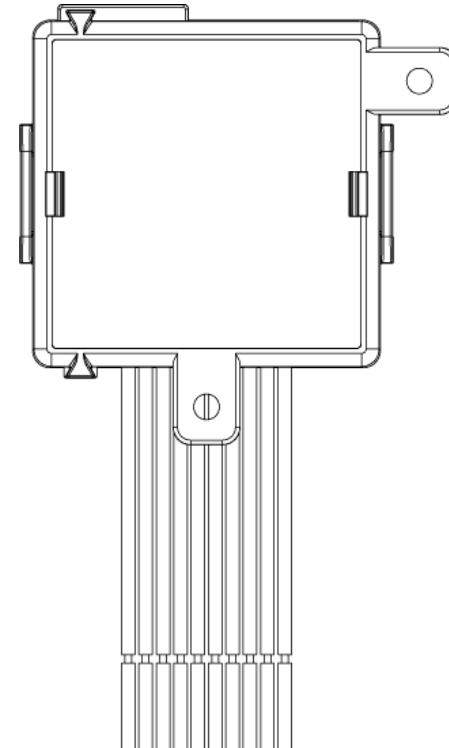
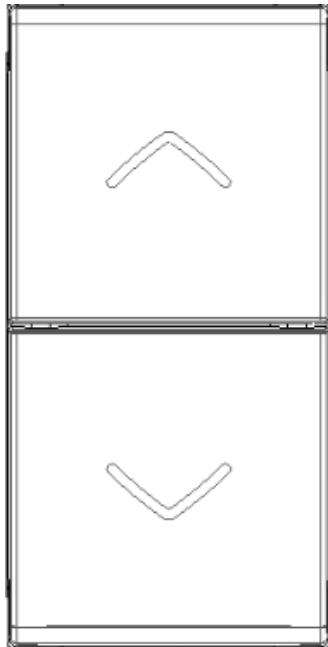

Smart-Home

Comando tapparella connesso

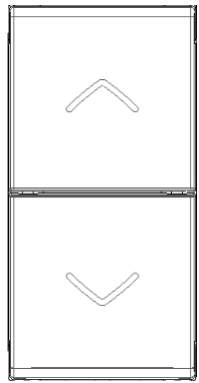

Retroilluminazione per individuazione al buio/stato del carico

Relè integrato con interblocco

Possibilità di estensione con comandi wireless

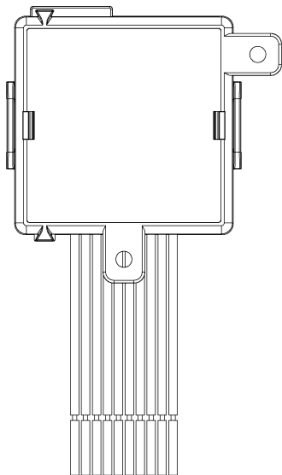

Smart-Home

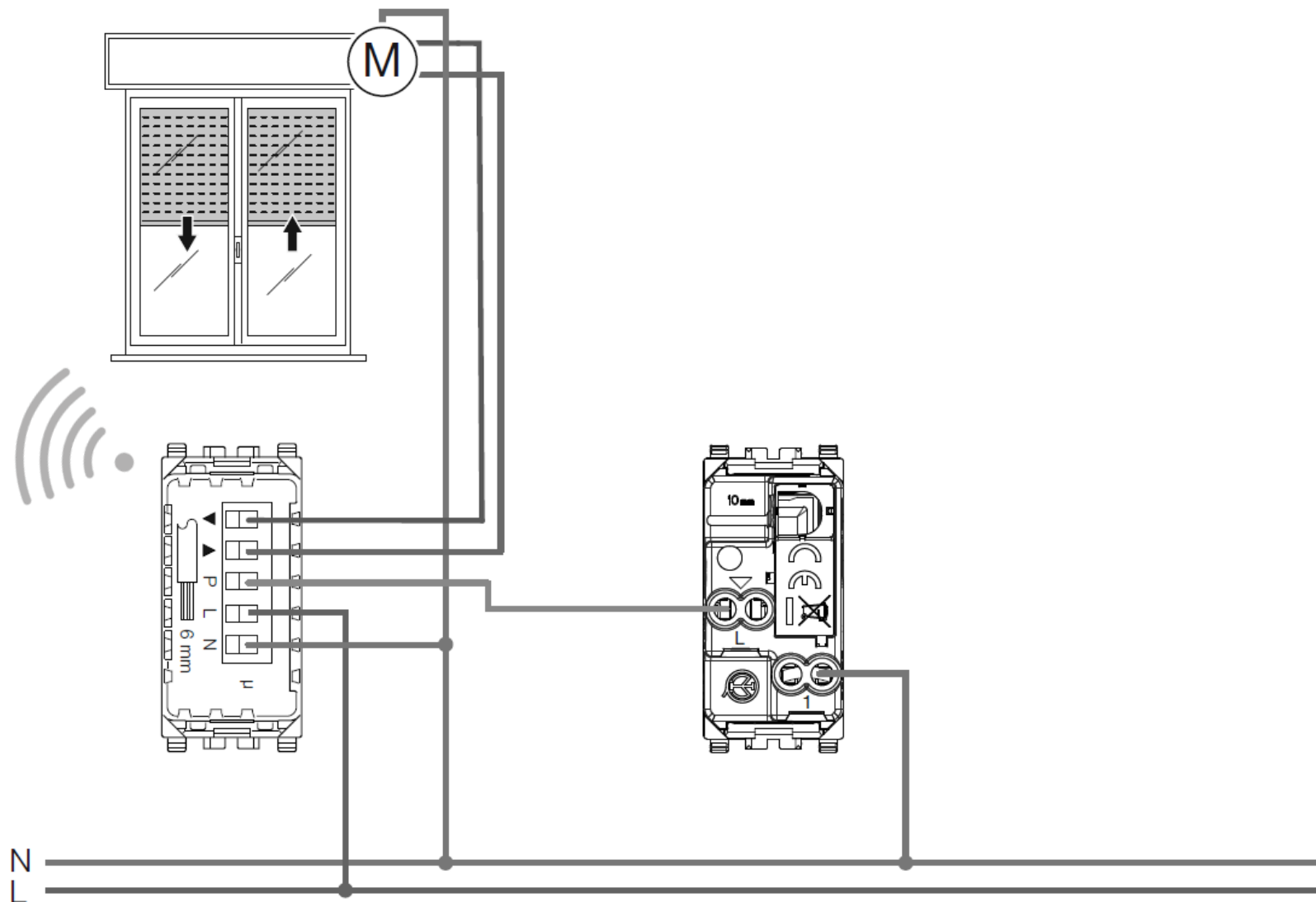

Smart-Home

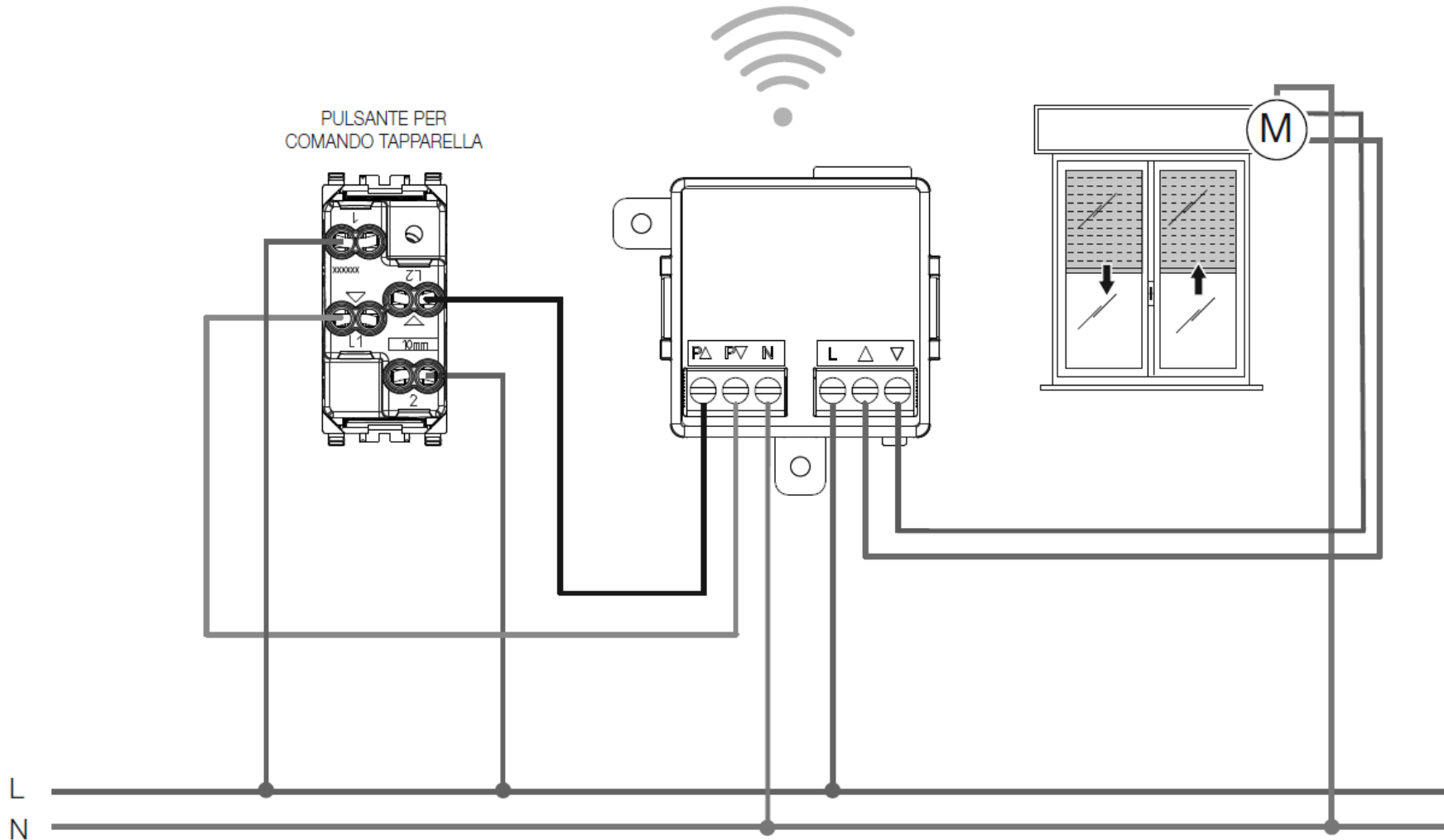

Smart-Home



Illuminazione

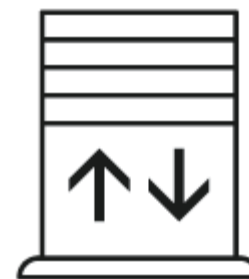
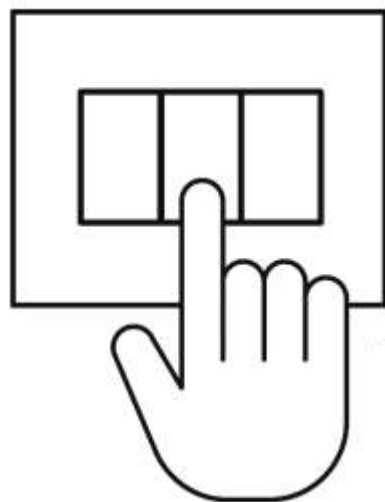

Tapparelle

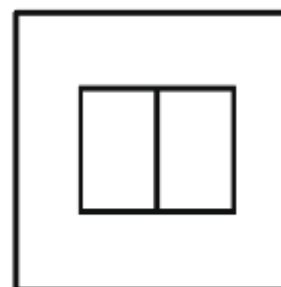

Smart-Home

Comando RF connesso

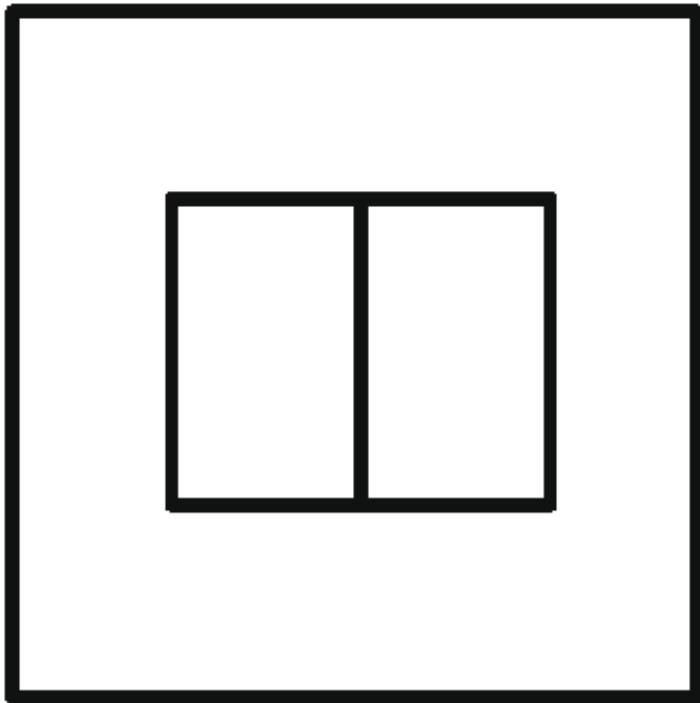

Versatile

Veloce da installare

Comando luci, tapparelle e scenari

Smart-Home



Illuminazione

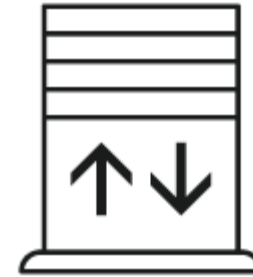
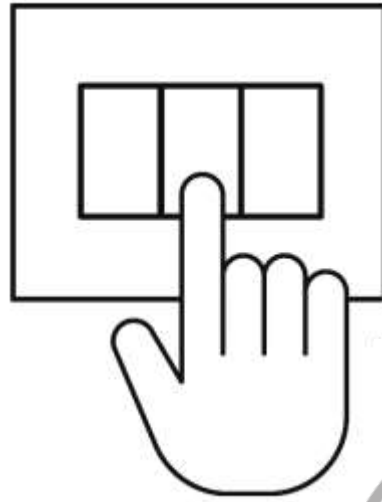

Tapparelle



Scenari

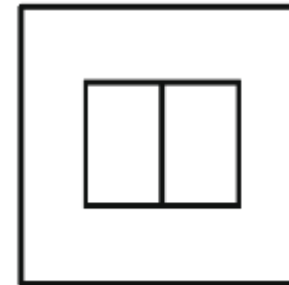

Comando RF

Smart-Home

Scenari

Da un unico punto comando
luci, tapparelle in modo
personalizzato



Smart-Home



Illuminazione

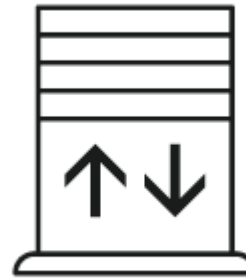
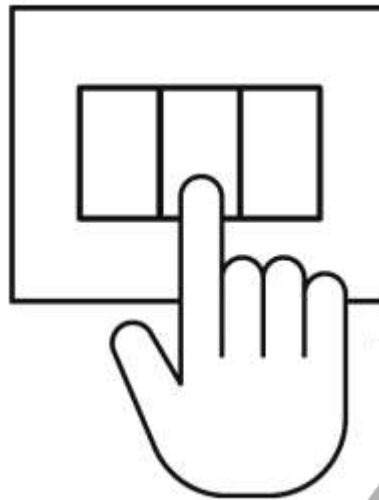

Tapparelle



Scenari



Monitor
Consumi

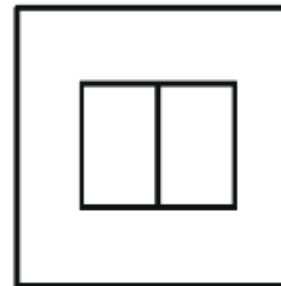

Comando RF

Smart-Home

Relè connesso

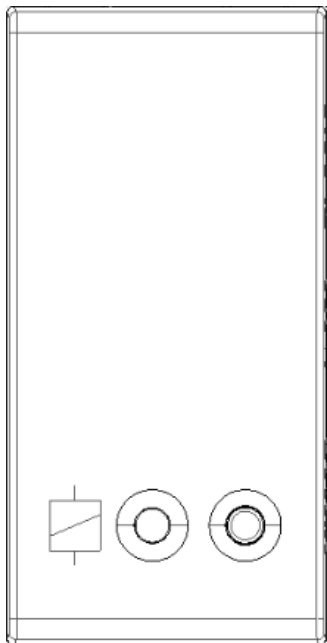

Retroilluminazione per individuazione al buio/stato del carico

Sensore di corrente integrato per distacco carichi

Possibilità di estensione con comandi wireless

Smart-Home

1. Esempio di collegamento al carico

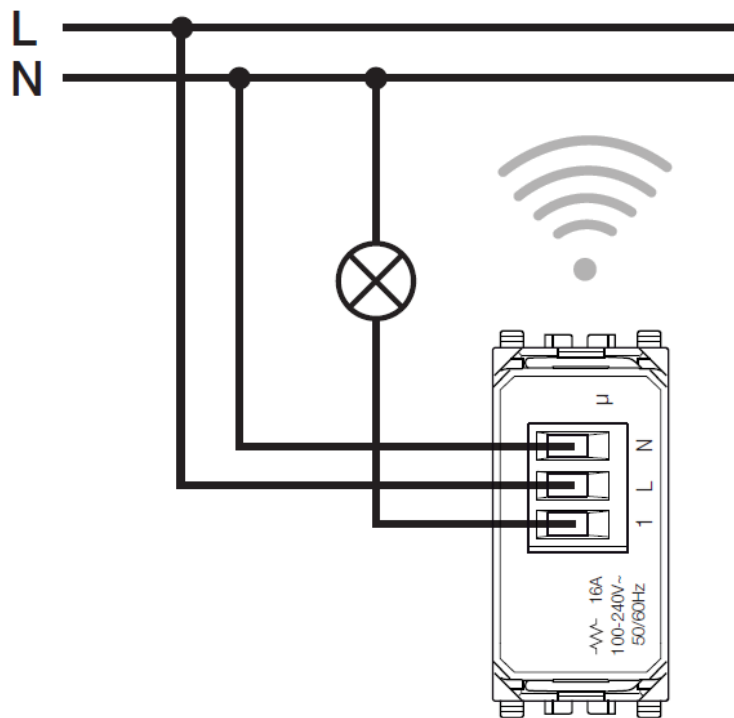

2. Esempio di collegamento alla presa

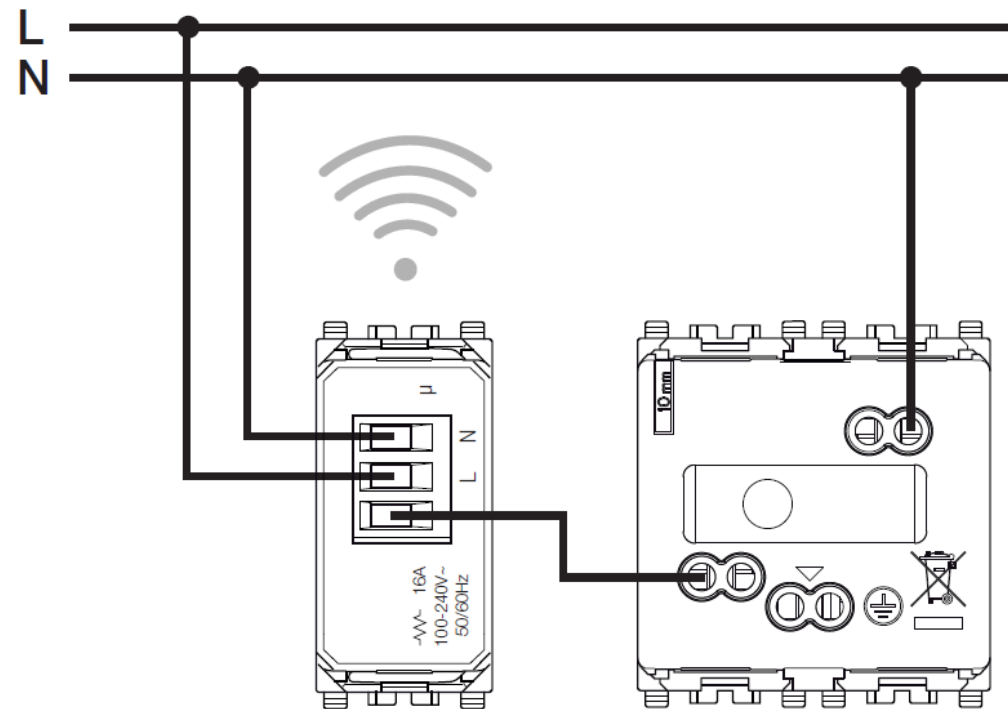

Smart-Home

Energy meter connesso



Misura consumo/produzione

Storicità

Funzione controllo carichi

Smart-Home

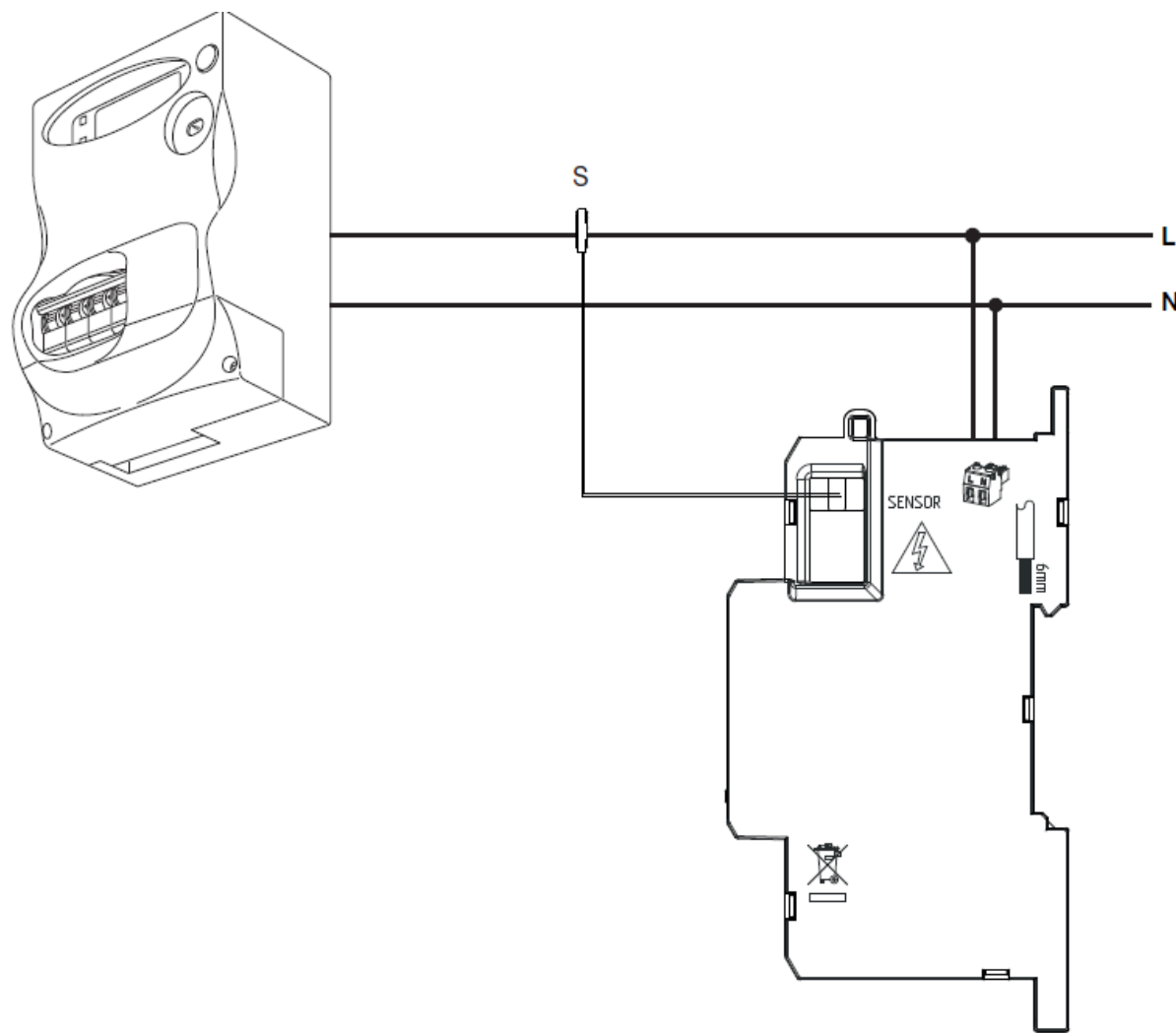

Smart-Home



Illuminazione

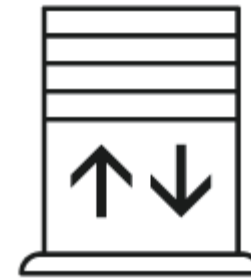
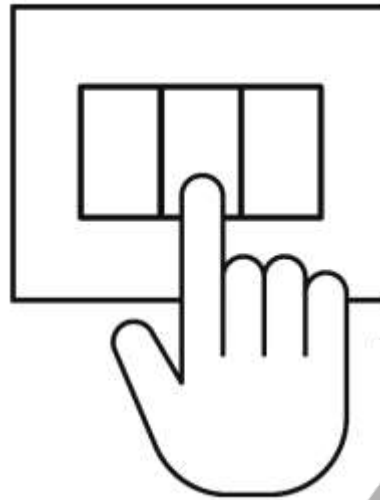

Tapparelle



Scenari



Monitor
Consumi

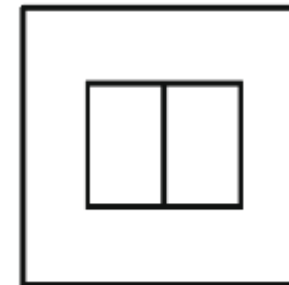

Comando RF

Smart-Home

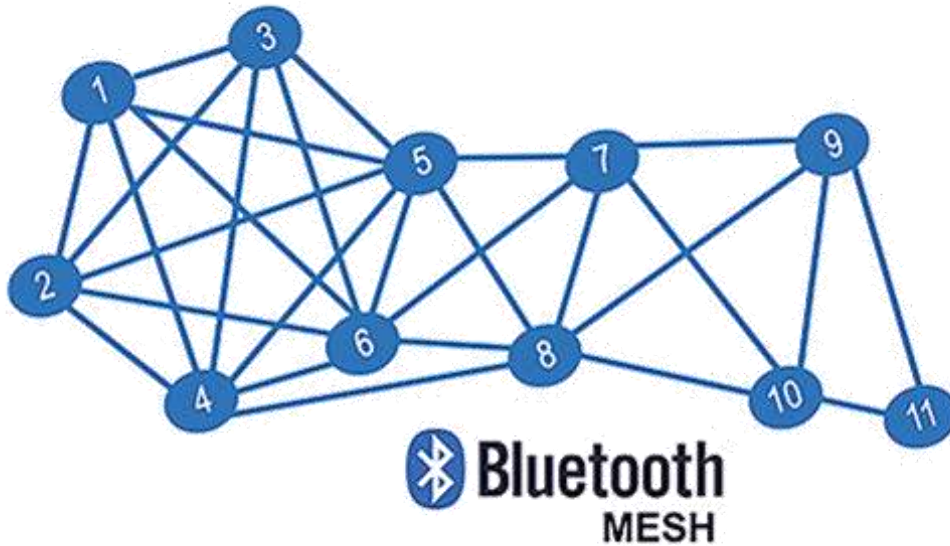

BLE 5.0

2MBps

2,4Ghz

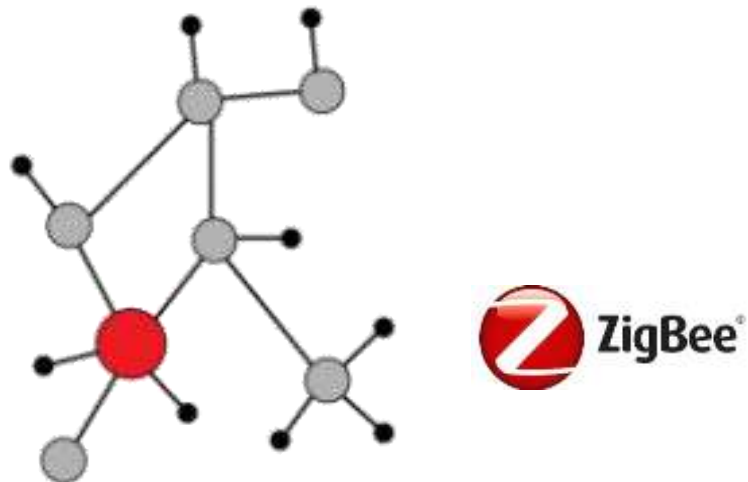

Necessita di bridge

30m portata

2,4Ghz

Integrazione

Smart-Home

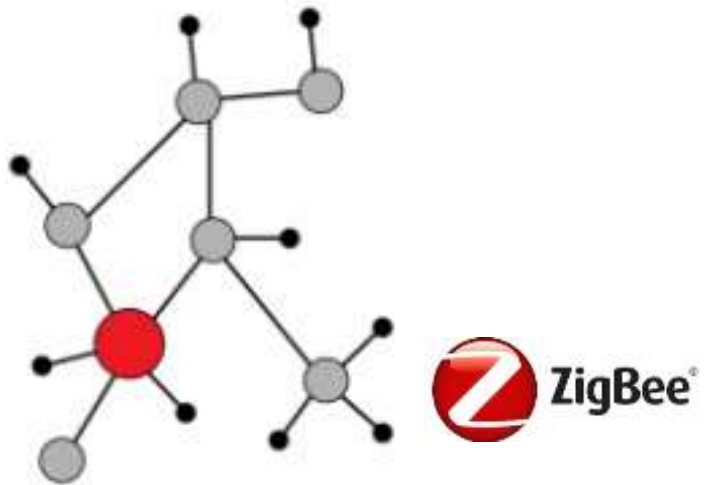
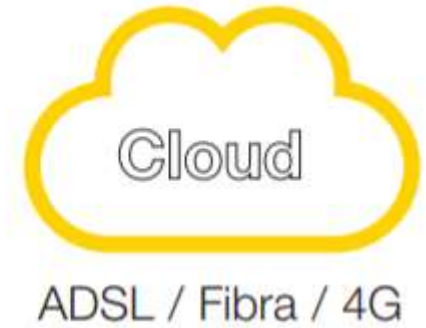
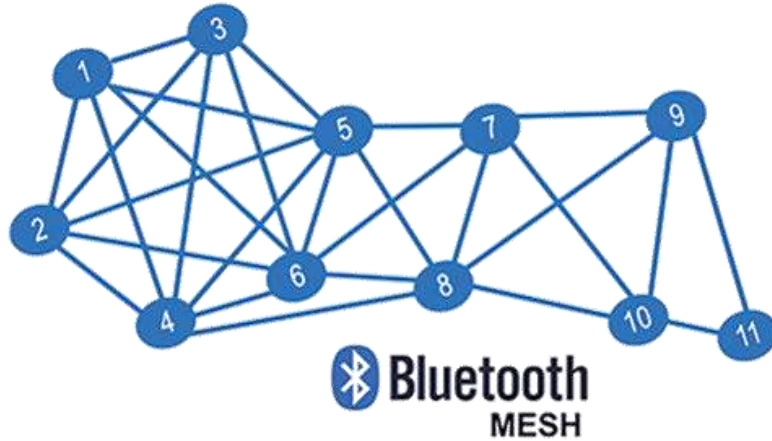

Smart-Home

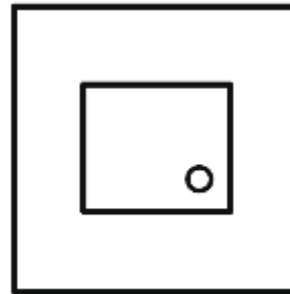
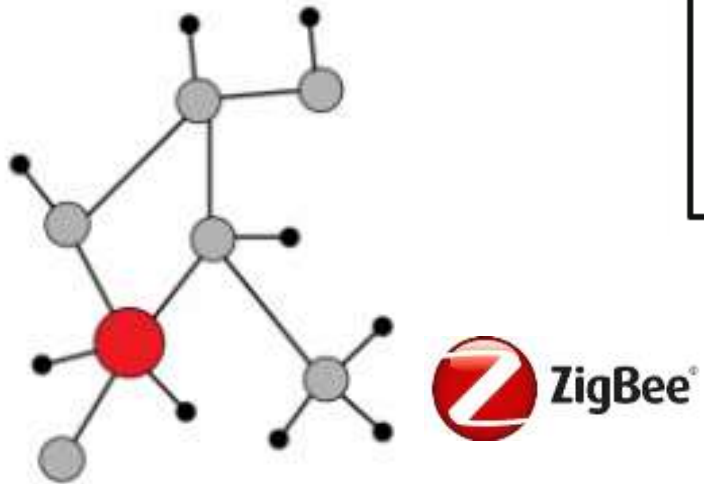
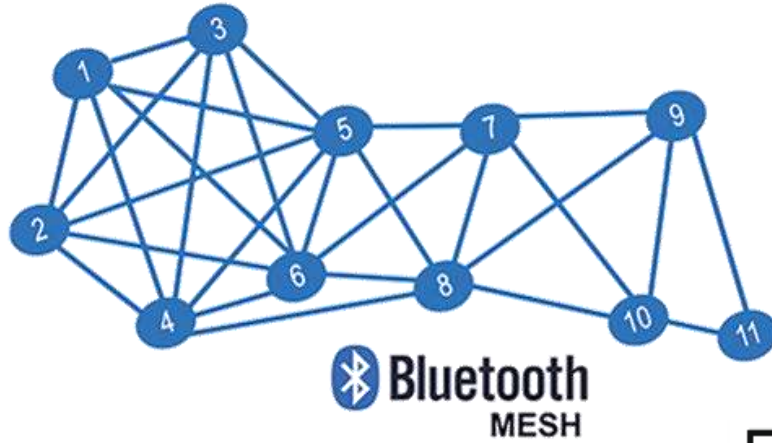

Gateway



Router Wi-Fi



ADSL / Fibra / 4G

Smart-Home

Gateway Wi-Fi BLE/Zigbee

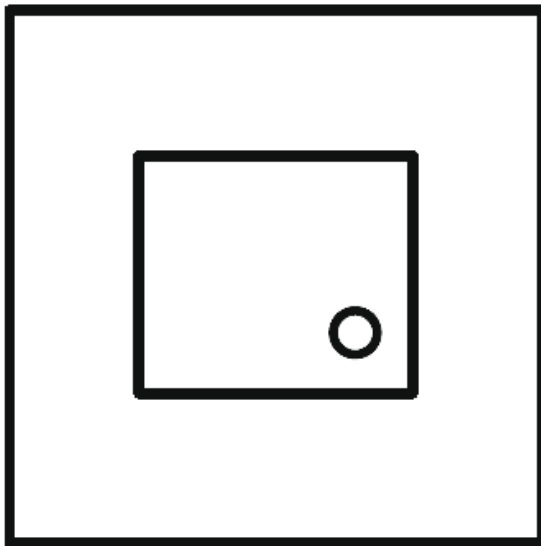

Integrazione Cloud

Integrazione smart speakers

Smart-Home

Visualizzare e controllare lo stato di luci, tapparelle o tende da sole e dei carichi connessi alle prese, ricevere notifiche.

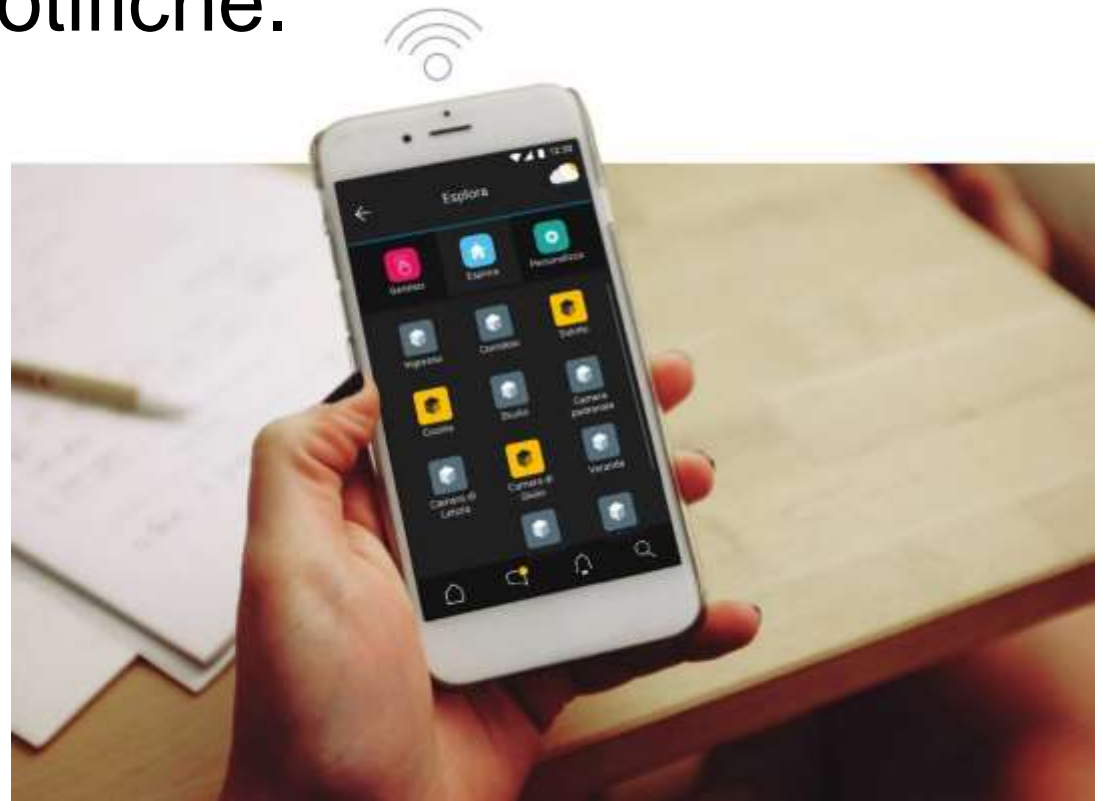

Smart-Home

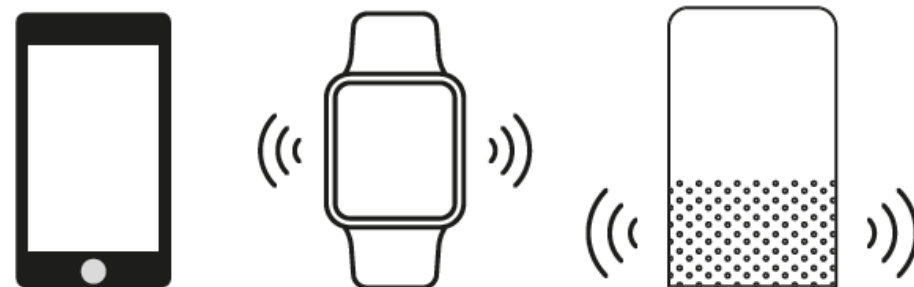

Works with
IFTTT

If  **Then**  **That**



Widget Home-Screen

Integrazione meteo

Geolocalizzazione

Scenari schedulati

Integrazione terze parti



VIMAR

energia positiva